

77, 78 and 79 Series

The CTS 77, 78 and 79 Series Filtered Assembly Plates provide ease of installation and line customization of standard size plates. Filter Plates are an efficient and cost effective solution for filtering multiple lines into, or between, different system compartments.

For higher frequency applications (above 50 MHz), filter plates can be more effective than typical surface mount solutions. The inherent shielding characteristic of the plates creates an effective RF barrier offering excellent insertion loss and isolation for frequencies above 5 MHz. The preassembled plates, which are 100% tested for critical parameters, greatly reduce the time and resources that are required to individually install solder mount filters.

The 77 Series Quick Connect and 78 Series Miniature Quick Connect Filter Plates (see pages 2-3) feature a base plate with built in installation clips. These clips allow for cost effective mounting into the system bulkhead without the expense or time associated with traditional hardware.

The Quick Connect Filter Plate offers one or two rows totaling up to 26 lines. The Miniature Quick Connect Filter Plate provides a lower profile and up to 10 lines. Up to 40 lines are available on the standard bolt-in filter plate in the two row configuration.

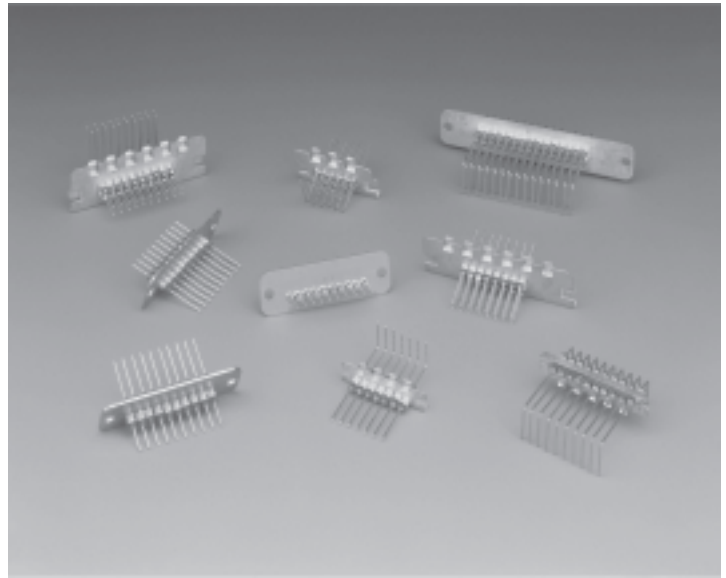

77, 78 and 79 Series Filter Plate Mechanical Specifications:

Base Plate Material	Copper Alloy or Nickel-Silver
Base Plate Thickness	
77 and 78 Series	0.012" [0.3mm]
79 Series	0.028" [0.7mm]
Plating	Matte Tin
Lead Material	Copper Alloy
Lead Plating	Gold Plate
Lead Diameter	Ø 0.025" [0.64mm]
Current Rating	5 Amps

Index

Quick Connect Filter Plates	pg. 2
Miniature Quick Connect Filter Plates	pg. 3
Standard Filter Plates	pg. 4
Ordering Information	pg. 5
Testing Information	pg. 6

Quick Connect Filter Plates

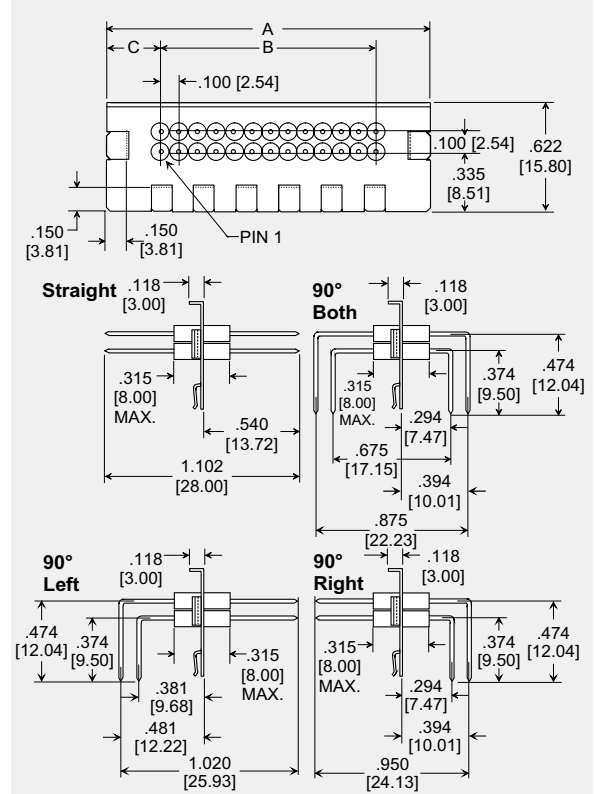
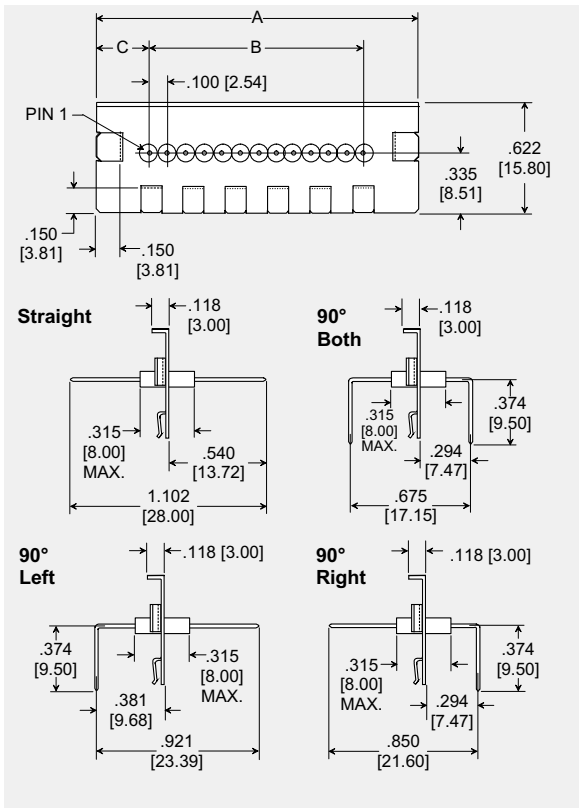

Plate Style 77

Mounting Configuration

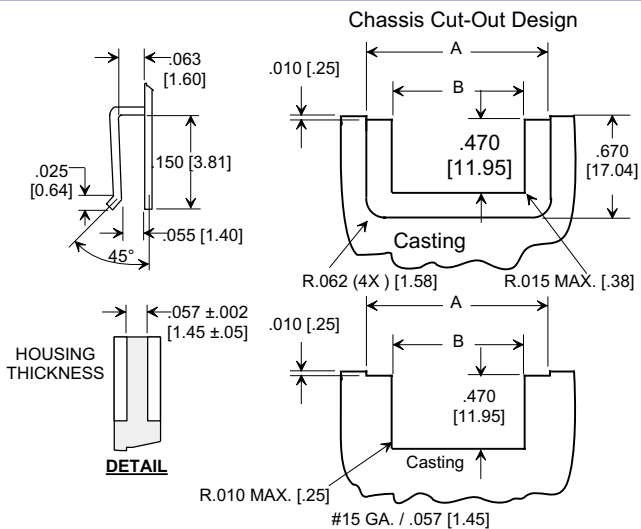
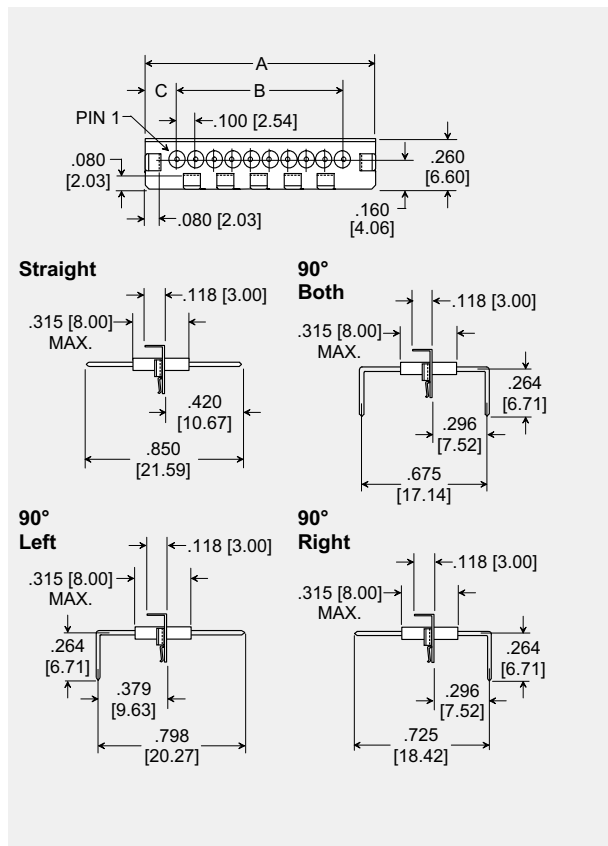

Plate Length	A	B
1.092 [27.74]	1.117 [28.37]	0.816 [20.73]
1.812 [46.02]	1.837 [46.66]	1.535 [38.99]

Plate length (A)	No. of filtered lines per row	B		C	
1.092 [27.74]	1	0.000	[0.00]	0.496	[12.60]
	2	0.100	[2.54]	0.496	[12.60]
	3	0.200	[5.08]	0.396	[10.06]
	4	0.300	[7.62]	0.396	[10.06]
	5	0.400	[10.16]	0.296	[7.52]
	6	0.500	[12.70]	0.296	[7.52]
1.812 [46.02]	1	0.000	[0.00]	0.906	[23.01]
	2	0.100	[2.54]	0.806	[20.47]
	3	0.200	[5.08]	0.806	[20.47]
	4	0.300	[7.62]	0.706	[17.93]
	5	0.400	[10.16]	0.706	[17.93]
	6	0.500	[12.70]	0.606	[15.39]
	7	0.600	[15.24]	0.606	[15.39]
	8	0.700	[17.78]	0.506	[12.85]
	9	0.800	[20.32]	0.506	[12.85]
	10	0.900	[22.86]	0.406	[10.31]
	11	1.000	[25.40]	0.406	[10.31]
	12	1.100	[27.94]	0.306	[7.77]
	13	1.200	[30.48]	0.306	[7.77]

Miniature Quick Connect Filter Plates



Mounting Configuration

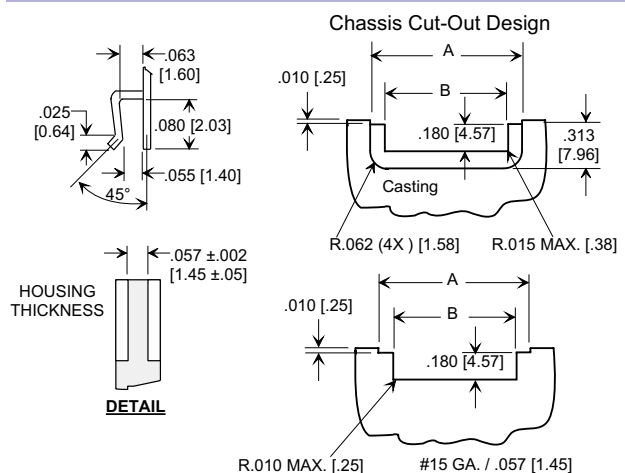

Plate Length	A	B
.990 [25.15]	1.015 [25.78]	0.846 [21.48]
1.24 [31.49]	1.265 [32.13]	1.096 [27.84]

Plate Style 78

Plate length (A)	No. of filtered lines per row	B		C	
.990 [25.15]	2	0.100	[2.54]	0.395	[10.03]
	3	0.200	[5.08]	0.395	[10.03]
	4	0.300	[7.62]	0.295	[7.49]
	5	0.400	[10.16]	0.295	[7.49]
	6	0.500	[12.70]	0.195	[4.95]
1.240 [31.49]	7	0.600	[15.24]	0.195	[4.95]
	2	0.100	[2.54]	0.570	[14.48]
	3	0.200	[5.08]	0.470	[11.94]
	4	0.300	[7.62]	0.470	[11.94]
	5	0.400	[10.16]	0.370	[9.40]
	6	0.500	[12.70]	0.370	[9.40]
	7	0.600	[15.24]	0.270	[6.86]
	8	0.700	[17.78]	0.270	[6.86]
	9	0.800	[20.32]	0.170	[4.32]
	10	0.900	[22.86]	0.170	[4.32]

CTS Miniature Quick Connect Filter Plates offer the same ease of installation as the larger Quick Connect Filter Plates, while offering a low profile for limited area applications.

These Quick Connect Filter Plates are available in two lengths offering up to 10 lines with the longer plate option. Each line can be customized using the electrical characteristics in the table on page 5. If other special requirements are needed, contact us.

Standard Filter Plates

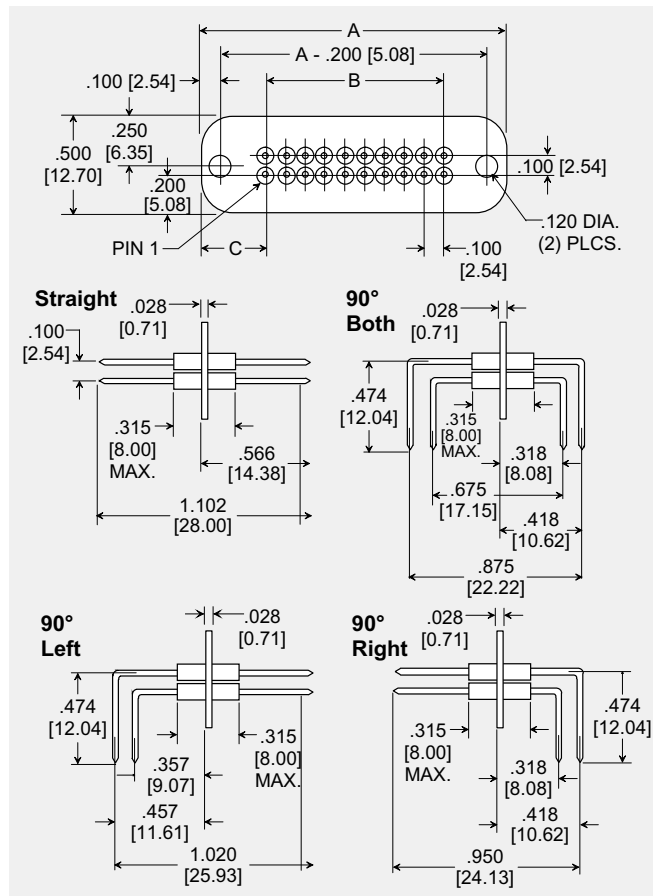
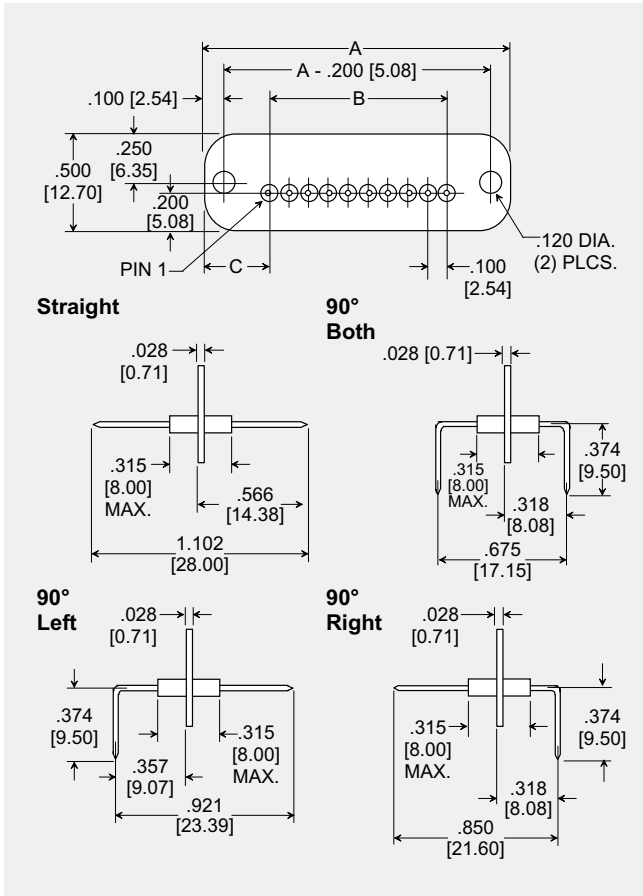

Plate Style 79

Plate length (A)	No. of filtered lines per row	B	C
No. 0	1	0.000 [0.00]	0.530 [13.46]
	2	0.100 [2.54]	0.430 [10.92]
1.060 [26.92]	3	0.200 [5.08]	0.430 [10.92]
	4	0.300 [7.62]	0.330 [8.38]
	5	0.400 [10.16]	0.330 [8.38]
No. 1	1	0.000 [0.00]	0.730 [18.54]
	2	0.100 [2.54]	0.730 [18.54]
	3	0.200 [5.08]	0.630 [16.00]
	4	0.300 [7.62]	0.630 [16.00]
	5	0.400 [10.16]	0.530 [13.46]
	6	0.500 [12.70]	0.530 [13.46]
	7	0.600 [15.24]	0.430 [10.92]
	8	0.700 [17.78]	0.430 [10.92]
	9	0.800 [20.32]	0.330 [8.38]
	10	0.900 [22.86]	0.330 [8.38]

Plate length (A)	No. of filtered lines per row	B	C
No. 2	5	0.400 [10.16]	1.030 [26.16]
	6	0.500 [12.70]	1.030 [26.16]
2.560 [65.02]	7	0.600 [15.24]	0.930 [23.62]
	8	0.700 [17.78]	0.930 [23.62]
	9	0.800 [20.32]	0.830 [21.08]
	10	0.900 [22.86]	0.830 [21.08]
	11	1.000 [25.40]	0.730 [18.54]
	12	1.100 [27.94]	0.730 [18.54]
	13	1.200 [30.48]	0.630 [16.00]
	14	1.300 [33.02]	0.630 [16.00]
	15	1.400 [35.56]	0.530 [13.46]
	16	1.500 [38.10]	0.530 [13.46]
	17	1.600 [40.64]	0.430 [10.92]
	18	1.700 [43.18]	0.430 [10.92]
	19	1.800 [45.72]	0.330 [8.38]
	20	1.900 [48.26]	0.330 [8.38]

Electrical Characteristics

Filter	Filter Circuits	Capacitance		Working Voltage -55°C/+125°C Vdc	Typical No Load Insertion Loss (dB) at +25°C per MIL STD 220							
		Value	Tolerance		5 MHz	10 MHz	20 MHz	50 MHz	100 MHz	200 MHz	500 MHz	1 GHz
A	C	68pF	+80/-20%	100V	--	--	--	--	--	3	10	16
B	C	100pF	+80/-20%	100V	--	--	--	--	1	6	14	19
C	C	135pF	+100/-0%	100V	--	--	--	1	5	10	16	20
D	C	470pF	+80/-20%	100V	--	--	2	7	12	17	23	27
E	C	820pF	+80/-20%	100V	--	2	6	12	18	23	29	33
F	C	1000pF	+80/-20%	100V	--	3	7	14	20	25	31	35
G	C	1500pF	+80/-20%	100V	1	5	10	16	22	27	33	37
H	C	2500pF	+100/-0%	100V	5	10	15	21	25	32	36	40
K	C	4000pF	+100/-0%	100V	9	15	20	25	30	34	41	45
N	Pi	68pF	+80/-20%	100V	--	--	--	--	1	5	15	20
O	Pi	100pF	+80/-20%	100V	--	--	--	--	2	9	22	28
P	Pi	135pF	+100/-0%	100V	--	--	--	1	5	16	24	32
Q	Pi	470pF	+80/-20%	100V	--	--	--	9	18	22	36	43
R	Pi	820pF	+80/-20%	100V	--	--	3	13	22	30	42	50
S	Pi	1000pF	+80/-20%	100V	--	2	7	16	24	36	48	55
T	Pi	1700pF	+100/-0%	100V	1	6	14	28	35	48	60	70
U	Pi	2500pF	+100/-0%	100V	3	9	16	28	41	52	62	70
V	Pi	5000pF	+100/-0%	100V	7	14	27	41	53	66	70	70
X	Filter Characteristics provided by customer				--	--	--	--	--	--	--	--
Y	insulated	10pF	Max.	100V	--	--	--	--	--	--	--	--
Z	ground contact	--	--	--	--	--	--	--	--	--	--	--

Ordering Information

In order for CTS to establish the exact configuration required, please provide the following encoded description number as outlined below. A CTS part number will then be assigned to meet your specific needs.

The part number shown below represents the Quick Connect 1.812 length with two rows of seven lines per row. The filters are pi circuits with a capacitance value of 1000pF and straight leads. **7712-0707-SA**

77	1	2 -	07	07 -	S	A
Plate Style	Plate Length	Filter Type	Bottom Row*	Top Row	Capacitance Value**	Lead Configuration
77= Quick Connect 78= Miniature QC 79= Standard	See tables pages 2,3,4	C=1 π=2	Number of Filters	Number of Filteres	See table above	A= Sraight B= 90° Right C= 90° Left D= 90° Both

To request custom filtering, mechanical or material requirements not shown in this catalog, please contact Customer Engineering at 520-744-0400.

*When ordering a Miniature Quick Connect or another plate with a single row of filters use the designation for the bottom row in the part number and enter a value of 00 in the top row of the part number.

* To select different filter values please use filter letter X in description and provide CTS with a table showing where each Filter will mount.

Table Example:

A	A	S	S	S
A	A	S	S	S

The assemblies shown in this catalog have been designed and subjected to the following test plan as is applicable for the individual components. The information shown can be used as a basis for assembly specifications. For additional information or special requirements, please contact us.

LOT ACCEPTANCE INSPECTION:

INSPECTION OR TEST	TEST METHOD PER MIL-STD-202 EXCEPT AS NOTED	POST TEST REQUIREMENTS
Visual and Mechanical		In accordance with applicable requirements.
Materials, Designs, Construction and Workmanship		
Physical Dimensions and Marking		
Capacitance	Method 305, 1KHz, 1±0.2 VRMS max. +25°C	Within specified tolerance.
Dissipation Factor	Method 305, 1KHz, 1±0.2 VRMS max. +25°C	4.0% max.
Dielectric Withstanding Voltage	Method 301, 2 seconds, 50mA max. charging current, 2.5 times WVDC.	No evidence of damage or breakdown.
Insulation Resistance	Method 302, 50mA max. charging current, 100 VDC, 2 minutes or as specified by individual variation.	Greater than 10,000 Megohms or 100 Ohm-Farads, Whichever is less.
Insertion Loss	MIL-STD-220, 50 Ohms, +25° C, no load	Per applicable requirements.
Solderability	Method 208	Per applicable requirements.

PERIODIC QUALITY CONFORMANCE INSPECTION:

A periodic component quality conformance inspection program consisting of environmental and reliability testing is in place to ensure that product integrity is consistently maintained.